

P&H **KOBELCO**

9050-TC

Hybrid-drive Truck Crane

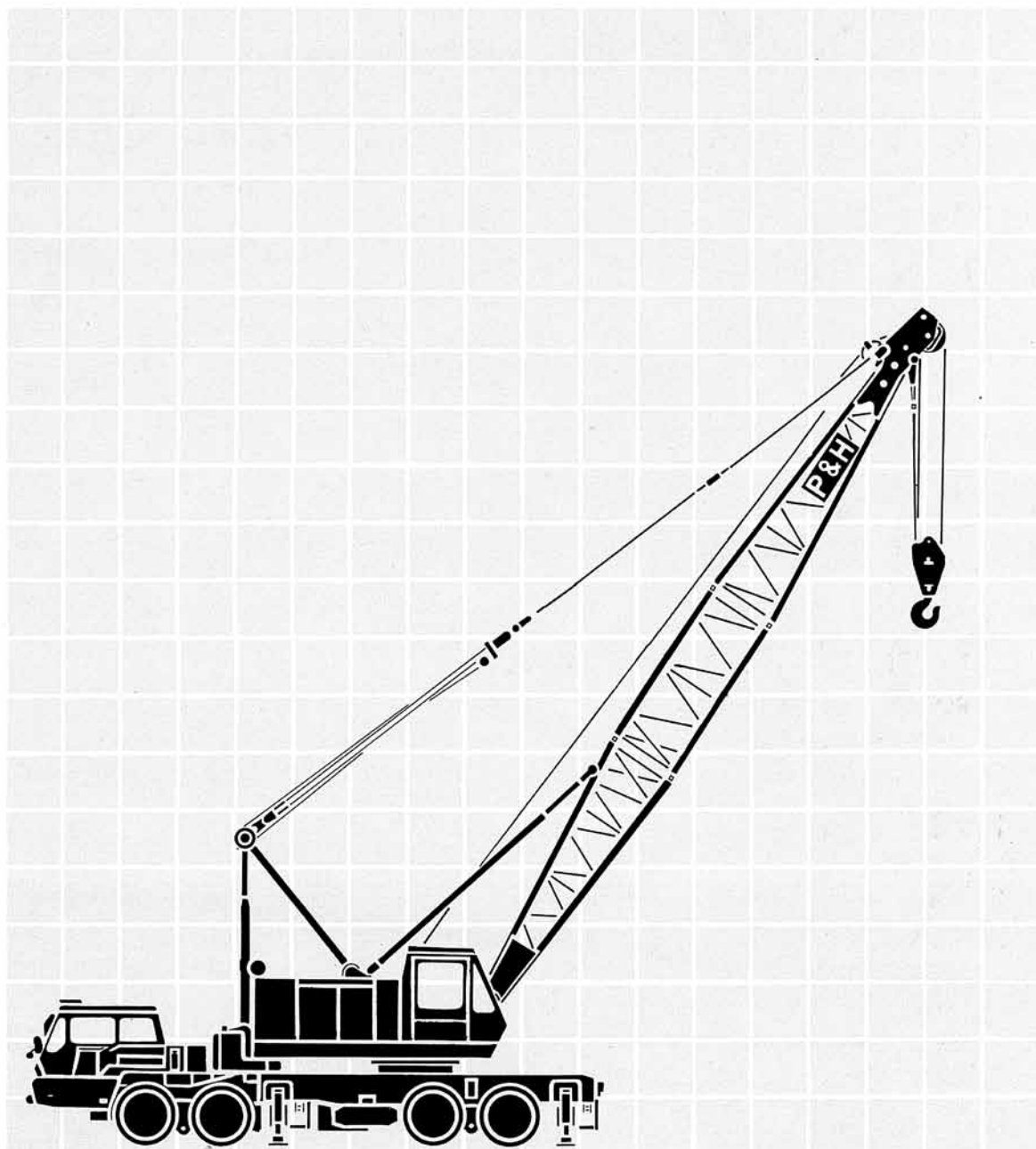

Bulliten No. 9050-101

Truck Crane

Rated lifting load on the boom for 360° swing (metric ton)

With side and rear outriggers fully extended

Operating Radius in Meters	12.19m (40') Boom	15.24m (50') Boom	18.29m (60') Boom	21.34m (70') Boom	24.38m (80') Boom	27.43m (90') Boom	30.48m (100') Boom	33.53m (110') Boom	36.58m (120') Boom	39.62m (130') Boom	42.67m (140') Boom	45.72m (150') Boom	48.77m (160') Boom	51.82m (170') Boom	Operating Radius in Meters
3.7	50.0														3.7
4.0	47.0														4.0
4.5	42.0	42.0	40.0												4.5
5.0	38.2	38.2	38.0	36.0											5.0
5.5	34.9	34.9	34.6	34.2	34.0										5.5
6.0	32.1	32.1	31.7	31.4	31.2	30.0									6.0
7.0	27.5	27.4	27.1	26.9	26.7	26.6	26.0								7.0
8.0	23.9	23.8	23.5	23.4	23.2	23.2	23.2	22.3	19.9						8.0
9.0	21.0	20.9	20.7	20.6	20.4	20.4	20.4	20.2	18.9	17.0	16.2				9.0
10.0	18.6	18.5	18.3	18.3	18.1	18.0	18.0	18.0	17.9	16.0	15.5	14.2	13.0		10.0
12.0	11m/16.3	14.8	14.8	14.8	14.6	14.5	14.3	14.2	14.1	14.0	14.0	13.7	12.1	10.2	12.0
14.0		12.1	12.1	12.1	12.1	12.0	11.7	11.6	11.4	11.4	11.3	11.2	11.1	9.4	14.0
16.0			10.2	10.1	10.1	10.1	9.9	9.7	9.5	9.5	9.4	9.3	9.3	8.5	16.0
18.0				8.6	8.6	8.6	8.4	8.3	8.1	8.0	7.9	7.9	7.9	7.7	18.0
20.0					7.4	7.4	7.3	7.2	7.0	6.9	6.8	6.8	6.8	6.7	20.0
22.0					6.4	6.4	6.3	6.2	6.1	6.1	5.9	5.9	5.9	5.9	22.0
24.0						5.6	5.5	5.5	5.4	5.3	5.2	5.2	5.1	5.1	24.0
26.0							4.9	4.9	4.8	4.7	4.6	4.6	4.5	4.5	26.0
28.0								4.3	4.2	4.2	4.1	4.1	4.0	4.0	28.0
30.0								3.9	3.8	3.8	3.7	3.6	3.6	3.5	30.0
32.0									3.4	3.4	3.3	3.3	3.2	3.1	32.0
34.0										3.1	3.0	2.9	2.8	2.8	34.0
36.0											2.7	2.6	2.5	2.4	36.0
38.0											2.4	2.3	2.2	2.1	38.0
40.0												2.1	2.0	1.9	40.0

*Stability is the limiting factor below the bold line and boom strength, above it.

Rated lifting load on the boom and 30° offset jib for 360° swing (metric ton)

With side and rear outriggers fully extended

Operating Radius in Meters	30.48m (100') Boom				33.53m (110') Boom				36.58m (120') Boom				39.67m (130') Boom				42.67m (140') Boom				45.72m (150') Boom				48.77m (160') Boom				Operating Radius in Meters	
	6.10 (20') Jib	9.14 (30') Jib	12.19 (40') Jib	15.24 (50') Jib	6.10 (20') Jib	9.14 (30') Jib	12.19 (40') Jib	15.24 (50') Jib	6.10 (20') Jib	9.14 (30') Jib	12.19 (40') Jib	15.24 (50') Jib	6.10 (20') Jib	9.14 (30') Jib	12.19 (40') Jib	15.24 (50') Jib	6.10 (20') Jib	9.14 (30') Jib	12.19 (40') Jib	15.24 (50') Jib	6.10 (20') Jib	9.14 (30') Jib	12.19 (40') Jib	15.24 (50') Jib	6.10 (20') Jib	9.14 (30') Jib	12.19 (40') Jib	15.24 (50') Jib		
10	6.0																													10
12	6.0	5.6			6.0					6.0							6.0													12
14	6.0	5.6	4.0		6.0	5.6	4.0			6.0	5.6					6.0	5.6				6.0	5.6								14
16	6.0	5.6	4.0	2.7	6.0	5.6	4.0	2.7		6.0	5.6	4.0				6.0	5.6	4.0			6.0	5.6	4.0							16
18	5.9	5.5	4.0	2.7	5.9	5.5	4.0	2.7	5.9	5.4	4.0	2.7	5.8	5.4	4.0	2.7	5.8	5.4	4.0	2.7	5.8	5.4	4.0	2.7	5.8	5.4	4.0			18
20	5.8	5.3	4.0	2.7	5.8	5.3	4.0	2.7	5.7	5.3	4.0	2.7	5.6	5.2	4.0	2.7	5.6	5.2	4.0	2.7	5.6	5.2	4.0	2.7	5.6	5.2	4.0	2.7		20
22	5.6	5.2	4.0	2.7	5.6	5.2	4.0	2.7	5.6	5.1	3.9	2.7	5.5	5.1	3.9	2.7	5.4	5.0	3.9	2.7	5.4	5.0	3.9	2.7	5.3	4.9	3.9	2.7		22
24	5.5	5.0	3.9	2.7	5.5	5.0	3.9	2.7	5.4	5.0	3.8	2.7	5.3	4.9	3.8	2.7	5.2	4.8	3.8	2.7	5.2	4.8	3.8	2.7	5.1	4.7	3.7	2.7		24
26	4.9	4.9	3.8	2.7	4.9	4.9	3.8	2.7	4.8	4.8	3.7	2.7	4.7	4.7	3.7	2.7	4.6	4.6	3.7	2.7	4.6	4.6	3.7	2.7	4.5	4.5	3.6	2.7		26
28					4.3	4.3	3.7	2.7	4.2	4.2	3.6	2.7	4.2	4.2	3.6	2.7	4.1	4.1	3.5	2.7	4.1	4.1	3.5	2.7	4.0	4.0	3.5	2.7		28
30					3.9	3.9	3.6	2.6	3.8	3.8	3.5	2.6	3.8	3.8	3.5	2.6	3.7	3.7	3.4	2.6	3.6	3.6	3.4	2.6	3.6	3.6	3.3	2.6		30
32									3.4	3.4	3.4	2.5	3.4	3.4	3.4	2.5	3.3	3.3	3.3	2.5	3.3	3.3	3.3	2.5	3.2	3.2	3.2	2.5		32
34										3.1	3.1	3.1	2.4	3.0	3.0	3.0	2.4	2.9	2.9	2.9	2.4	2.8	2.8	2.8	2.4	2.8	2.8	2.4		34
36														2.7	2.7	2.7	2.3	2.6	2.6	2.6	2.3	2.5	2.5	2.5	2.2	2.5	2.5	2.2		36
38														2.4	2.4	2.4	2.2	2.3	2.3	2.3	2.2	2.2	2.2	2.2	2.2	2.2	2.2	2.1		38
40																					2.1	2.1	2.1	2.1	2.0	2.0	2.0	2.0		40

Notes: 1. Operating radius is the horizontal distance from the swing axis to the center of gravity of the load.

2. Ratings do not exceed 78% of the tipping load, and include the weights of hook block(s), slings and all other load handling accessories.

3. Ratings shown are based on freely suspended loads and make no allowance for such factors as wind effect on the lifted load, out-of-level ground conditions, operating speeds or any other condition that could be detrimental to the safe operation of this equipment. The operator, therefore, has the responsibility to judge the prevailing conditions and reduce lifted loads and operating speeds accordingly.

4. Operation is not possible in the ranges indicated by blank spaces in the charts.

5. Boom inserts and guy cables must be arranged as shown in the "Owner's and Operator's Manual".

6. When only the boom is fitted, deduct the following weights from the rated lifting load to obtain the liftable load: main hook + wire rope slings + all

other load handling accessories.

7. When the jib is fitted, deduct the following weights from the rated lifting load to obtain the liftable load: main hook + jib hook + wire rope slings + all other load handling accessories.

8. When the jib is fitted, but the auxiliary sheave is rigged for boom-end lifting, the boom lifting capacity must be calculated by deducting the following weights according to the jib length from ratings shown.

Auxiliary sheave	300kg	6.10m jib	900kg
9.14m jib	1100kg	12.19m jib	1300kg
15.24m jib	1500kg		

Liftable loads must be calculated by deducting the weight of the main and auxiliary hook blocks, slings and all other load handling accessories from the ratings shown.

9. The jib can only be used with main boom lengths between 30.48m and 48.77m.

Boom modular build up

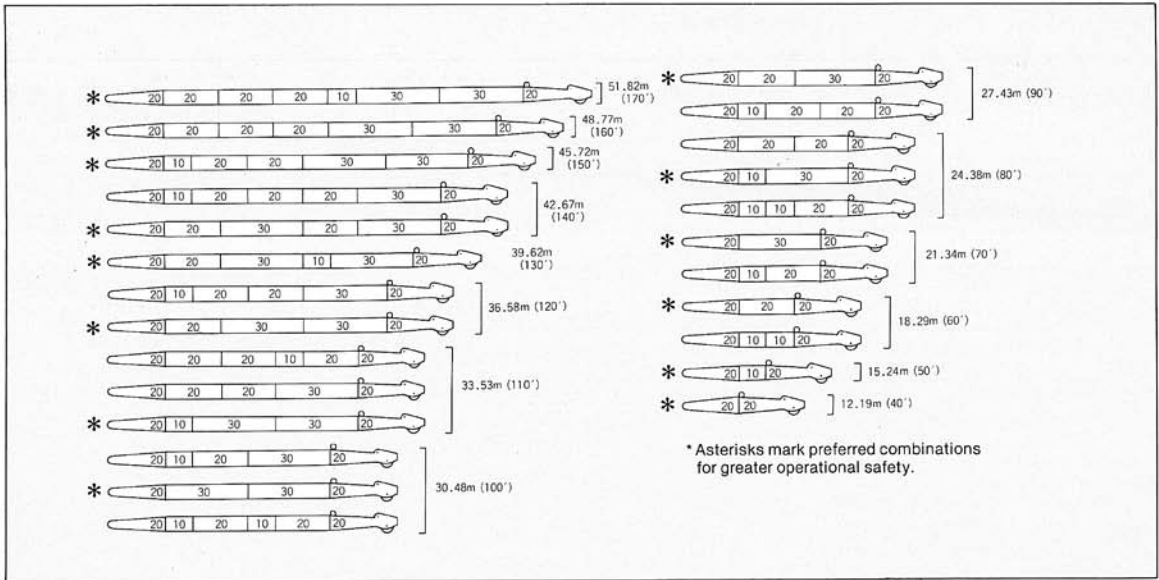

Rated lifting load per hoisting rope and hook weight

Hook capacity (ton)	Maximum rated load (ton)									Hook weight (ton)
	1 rope	2 ropes	3 ropes	4 ropes	5 ropes	6 ropes	7 ropes	8 ropes	9 ropes	
50	6	12	18	24	30	36	42	48	50	0.65
35	6	12	18	24	30	35				0.55
25	6	12	18	24	25					0.48
15	6	12	15							0.40
6	6									0.16

• Working range

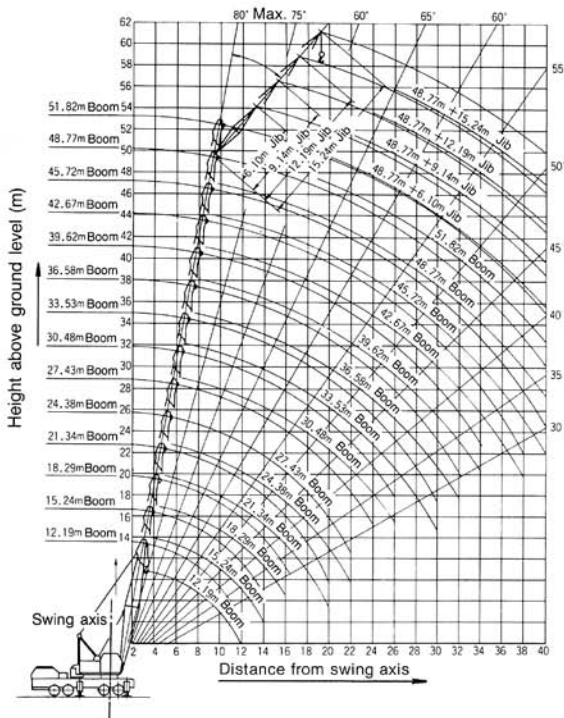

• Knocked-down transportation weights and dimensions

No.	Part	Weight (metric ton)	Dimensions (W) × (H) × (L)	Q'ty
1	Upper machinery with gantry (note 1)	11.75	3.1 × 2.64 × 6.31	1
2	Upper spreader	0.25	1.10 × 0.3 × 1.38	1
3	Counterweight	11.20	1.39 × 0.81 × 3.1	1
4	Outer boom section (note 2)	1.02	1.38 × 1.98 × 6.49	1
5	Inner boom section (note 3)	1.00	1.38 × 1.64 × 6.25	1
6	3.05m boom insert (note 2)	0.39	1.37 × 1.47 × 3.15	1
7	6.10m boom insert (note 2)	0.61	1.37 × 1.47 × 6.20	3
8	9.14m boom insert (note 2)	0.79	1.37 × 1.47 × 9.25	2
9	Outer jib section	0.17	0.57 × 0.47 × 3.38	1
10	Inner jib section (note 4)	0.13	0.68 × 0.56 × 3.19	1
11	3.05m jib insert (note 5)	0.10	0.57 × 0.47 × 3.12	1
12	6.10m jib insert (note 5)	0.17	0.57 × 0.56 × 6.16	1
13	Jib straddle	0.16	0.62 × 0.45 × 3.71	1
14	50t hook block	0.65	0.44 × 0.58 × 1.59	1
15	35t hook block	0.55	0.42 × 0.58 × 1.42	1
16	25t hook block	0.48	0.33 × 0.58 × 1.44	1
17	15t hook block	0.40	0.33 × 0.58 × 1.19	1
18	6t ball hook	0.16	0.30 × 0.30 × 0.85	1

- Notes:
- The lower spreader is included with the upper machinery.
 - Guy cables and connecting pins are included with the outer boom section and boom inserts.
 - Back stops are included with the inner boom section.
 - Guy cables and connecting pins are included with the inner jib section.
 - Connecting pins are included with the jib inserts.
 - A 35ton class crane is needed to assist with mounting and dismantling the upper machinery from the truck.

Clamshell Attachment

■ Specifications

● Performance		
Max. lifting capacity	ton × m	5.5 × 16
Max. boom length	m	18.29
Max. boom hoisting line speed*	m/min	49
Max. boom lowering line speed*	m/min	31
Max. holding line speed (hoisting)*	m/min	60
Max. closing line speed (hoisting)*	m/min	60
Max. swing speed	rpm	3.0
Operating weight	ton	53.3 (standard boom with 2.0m ³ bucket)
● Wire ropes		
Wire rope dia. for boom hoisting	mm	16
Wire rope dia. for holding	mm	22
Wire rope dia. for closing	mm	22
Boom guy line dia.	mm	30

*Operating speed figures are for one drum.

■ Rated clamshell load (metric ton)

Operating radius (m)	Boom length (m)		
	12.19	15.25	18.29
7	5.5		
8	5.5	5.5	
9	5.5	5.5	5.5
10	5.5	5.5	5.5
12	5.5	5.5	5.5
14		5.5	5.5
16			5.5

■ Buckets

Capacity (m ³)	Bucket weight (metric ton)	Use
0.6	2.1	digging
0.8	2.5	digging
1.2	3.1	gravel loading
2.0	2.0	coal loading

Lifting Magnet Attachment

■ Main specifications

Magnet type	180H
Max. rated load (metric ton)	5.5
Max. boom length (m)	18.29

*Operating with a lifting magnet larger than 180H voids the warranty.

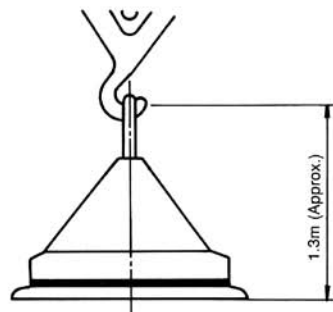

Principal Dimensions

Unit: mm

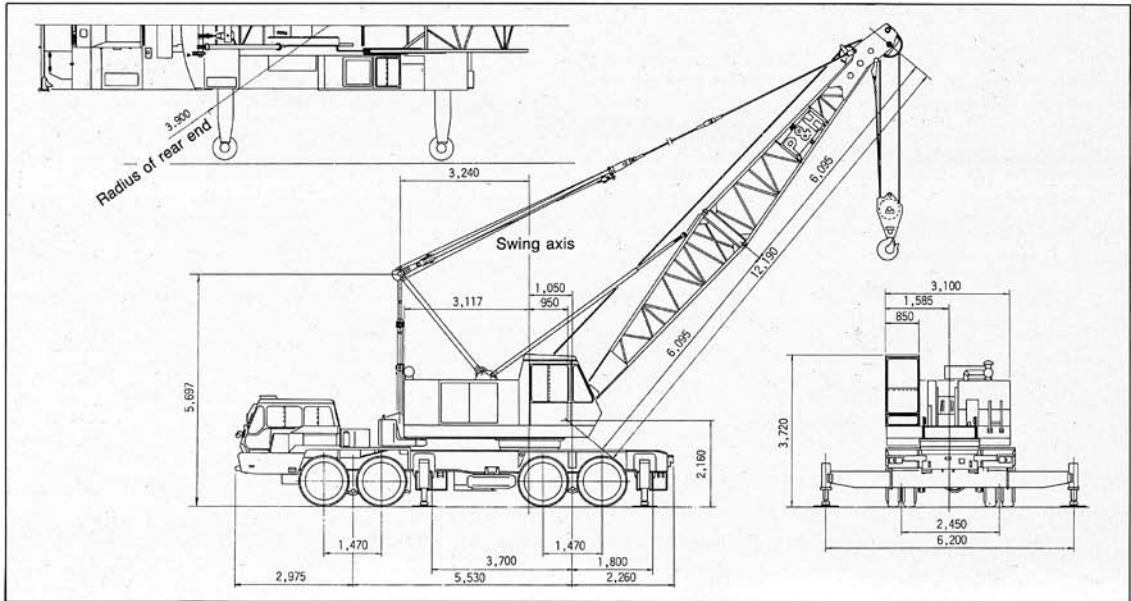

Specifications

● Performance			
Max. lifting capacity	ton × m		50 × 3.7
Min. boom length	m		12.19
Max. boom length	m		51.82
Max. jib length	m		15.24
Max. boom length with jib	m		48.77 (boom) + 15.24 (jib)
Main hook hoisting speed (high/low)*	m/min		60/36
Main hook lowering line speed using power (high/low)*	m/min		38/23
Boom hoisting line speed (high/low)*	m/min		49/30
Boom lowering line speed (high/low)*	m/min		31/19
Aux. hook hoisting line speed (high/low)*	m/min		60/36
Aux. hook lowering line speed using power (high/low)*	m/min		38/23
Swing speed	rpm		3.0
● Weights			
Operating weight (approx.)	metric ton		52 (with counter weight, 12.19m boom and 50t hook block)
Carrier weight (approx.)	metric ton		22.59
● Wire ropes			
Main hoisting rope dia.	mm		22
Boom hoisting rope dia.	mm		16
Aux. hoisting rope dia.	mm		22
Boom guy line dia.	mm		30
Jib guy line dia.	mm		20
● Crane drive			
Engine	Model		Nissan PD604 diesel engine
	Type		4-stroke, water-cooled with direct injection
	Power output	PS/rpm	152/2,000
Transmission			Power shift, 2-speed transmission and PTO for hydraulic pump drive
● Carrier			
Model			Nissan P-KG 52V with hydraulic outriggers and 8 × 4 drive
Travel speed	km/h		60
Gradeability	tan°		0.38
Min. turning radius	m		11.9
Engine	Model		Nissan PE8 diesel engine
	Type		4-stroke, water-cooled V 8-cylinder with direct injection
	Max. output PS/rpm		315/2,300
Outriggers			H-type

*Operating speed figures are for one drum.

P&H **KOBELCO** **9050-TC**

NOTE: Due to our policy of continual product improvement, all designs and specifications are subject to change without advance notice. Data herein is informational in nature and shall not be construed to warrant suitability of the machine for any particular purpose as performance may vary with the conditions encountered. These statements are correct at time of going to press.



CONSTRUCTION MACHINERY DIVISION

Tokyo Head Office:

Tekko Bldg.

No. 8-2, Marunouchi 1-chome, Chiyoda-ku, Tokyo, Japan

Phone: Tokyo (03) 281-7881

Cable: "KOBESTEEL TOKYO"

Telex: No. 222-3601 (KOBESTEEL TOK)

Construction Machinery Plant:

123, Fukuda, Okubo-cho, Akashi-city, Japan

Phone: Akashi (078) 936-1331

Cable: "KOBESTEEL AKA"

Telex: No. 5628944 (KOBESTL J)

Address inquiries to: